

# OPERATION AND MAINTENANCE MANUAL

## PF-20 Series

### Permanent Media Filters

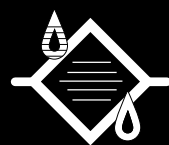

# **PUROFLUX**

**C O R P O R A T I O N**  
**F I L T R A T I O N A N D C O N T R O L S Y S T E M S**

## PF-20 SERIES PERMANENT MEDIA FILTERS

Please read this OPERATION AND MAINTENANCE MANUAL thoroughly and understand all safety related issues before attempting any work on the PF-20 series filter.

### INTRODUCTION

PUROFLUX is the right choice when it comes to having a more efficient, safe, and effective system. The PF-20 series filters are designed to assist in eliminating expensive "down-time," reducing operating costs, chemical usage, wear and tear on equipment and maintenance. With over 30 years of combined filtration experience, PUROFLUX engineers can find a solution to a wide variety of filtration problems.

Following the guidelines listed in this manual will help to insure the safety of all personnel who maintain the filter unit and related equipment. If there are any questions on the procedures or performance of the PF-20 series filters contact the local factory representative or call the factory direct at (805)579-0216. **Do Not**, operate the filter until all questions about operating procedures are answered by a qualified representative. This manual covers recommended procedures for installation and anchoring, start-up and shut down, and safety and maintenance.

NOTE: All recommendations are minimums. The environment/operating conditions in which the filter unit is installed will dictate the frequency of scheduled maintenance. Maintaining your PF-20 series filter will assure a long trouble free life.

NOTE: Puroflux reserves the right to change, modify, or revise this manual at any time without prior notification.

Puroflux Corporation  
1357 Kuehner Drive, Simi Valley, CA 93063  
Phone (805)579.0216 • Fax (805)579.6005  
Website: [www.puroflux.com](http://www.puroflux.com)  
E-Mail: [sales@puroflux.com](mailto:sales@puroflux.com)

# TABLE OF CONTENTS

**SECTION 1**

|                              |   |
|------------------------------|---|
| Receiving and Installation   | 4 |
| Receiving Equipment          | 4 |
| Design Criteria              | 5 |
| Support and Lifting          | 5 |
| Installation and Anchoring   | 5 |
| Piping Interface Connections | 6 |
| Loading Media                | 7 |
| Electrical Controls          | 8 |
| Wiring Requirements          | 9 |

**SECTION 2**

|                             |    |
|-----------------------------|----|
| Theory of Operation         | 10 |
| Operation and Maintenance   | 10 |
| General Maintenance         | 10 |
| 24 Hour Time Clock Settings | 11 |
| Pump Pre-Strainer           | 12 |
| Pump and Motor              | 12 |
| Cleaning and Adjusting Pump | 12 |
| Filter Vessel               | 13 |
| Backwash Cycle              | 13 |
| Start-Up Procedure          | 14 |
| Operation In Cold Weather   | 15 |
| Shutdown                    | 15 |
| Recommended Spare Parts     | 16 |
| Fluid Treatment             | 16 |
| Safety                      | 16 |

**SECTION 3**

|          |    |
|----------|----|
| Warranty | 17 |
| Figure 3 | 18 |

# SECTION 1

## RECEIVING AND INSTALLATION

Recommended procedures for the receiving of equipment and proper installation of the PF-20 series permanent media filter.

### RECEIVING EQUIPMENT

Before accepting the filter equipment and prior to signing the bill of lading, all equipment should be checked thoroughly for any shipping damage. Make sure that all required equipment noted on the bill of lading is received. Refer to Figure 1 and Table I for components to be inspected upon receiving.

Check the model and serial number against the packing slip. Serial and model numbers can be found on a nameplate inside the control cabinet (automatic unit) or on the vessel skid (manual unit).

| Table I - Receiving / Inspection |
|----------------------------------|
| Filter Vessel                    |
| Control Panel (Automatic Units)  |
| Pump & Motor                     |
| Pump Pre-strainer                |
| Gauge Kit                        |
| Valves & Linkage                 |
| Actuator (Automatic Units)       |
| Face Piping                      |
| Media                            |

Figure 1

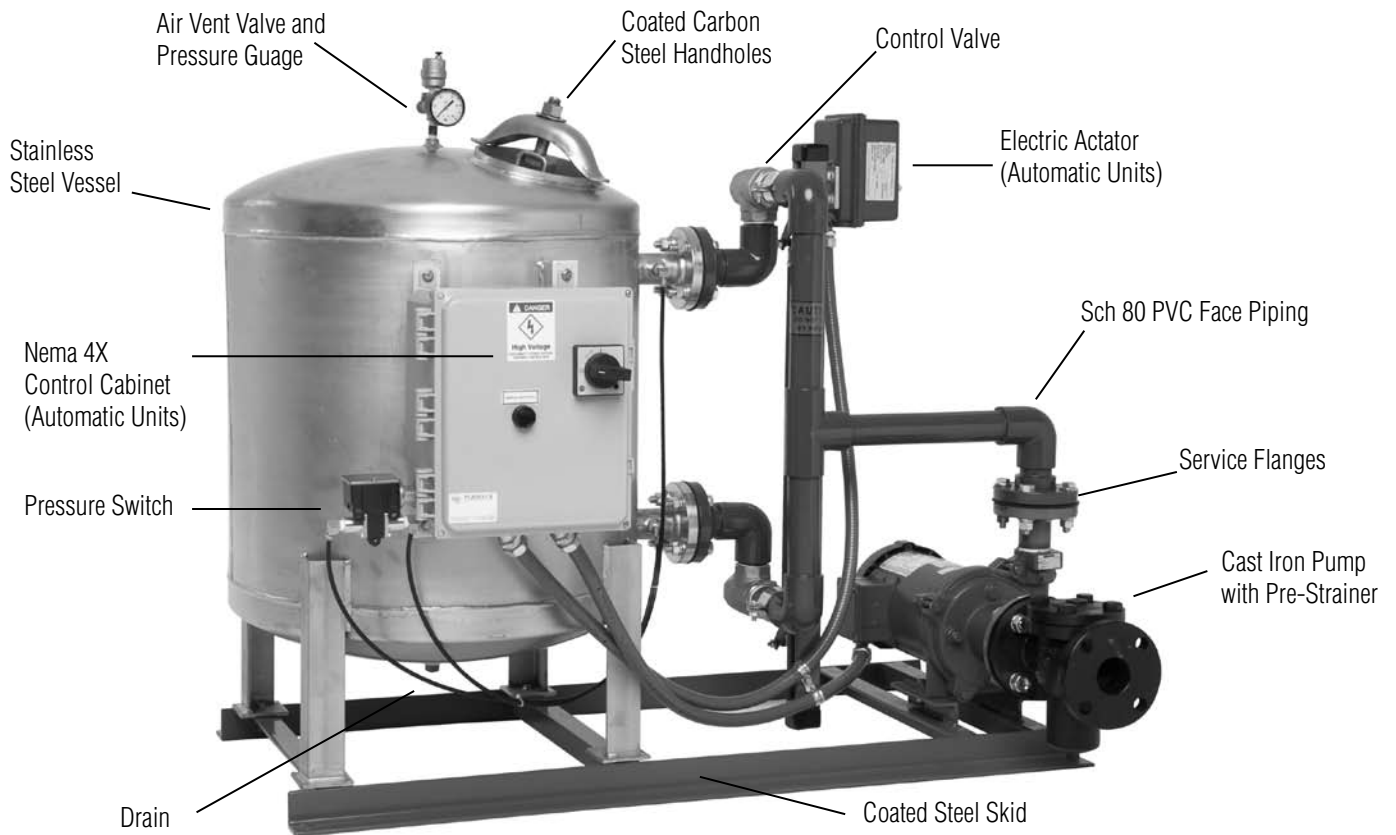

## DESIGN CRITERIA

The PUROFLUX PF-20 series filter is designed for use in both open and closed (75 psi or less) process liquid filter applications (higher design pressures are available). The PF-20 series filter with standard media will remove suspended solids down to 10 microns (optional 5 micron and lower media is available).

The PF-20 series filter is constructed of a stainless steel vessel with coated carbon steel handholes, industrial grade ball valves, Sch 80 PVC interconnecting piping, cast iron pump, and cast iron pre-strainer with removable stainless steel basket.

**NOTE:** Never install the PF-20 series filter in an application where the system pressure exceeds the filter design pressure.

## SUPPORT AND LIFTING

The PF-20 series filter can be lifted from the bottom of the filter skid with the skid fully supported. If the unit is hoisted, lifting straps must be placed under the bottom of the filter skid and should not come in contact with the filter components.

## INSTALLATION AND ANCHORING

The PF-20 series filter is designed for slip stream use on non-pressurized open sump or pressurized closed system applications. The PF-20 series filter should be located as close to the sump or interface piping as possible and never install in full flow system piping.

The PF-20 filter can be rigidly anchored to the floor using 1/2 inch anchor bolts. Refer to the specification drawing for location of anchor holes.

After the PF-20 series filter is installed in its permanent location, the gauge kit should be installed on the top of the filter vessel (refer to Figure 1).

**NOTE:** The PF-20 filter should not be installed more than 8 feet above the process liquid operating level.

## PIPING INTERFACE CONNECTIONS

The filter piping should be installed as follows:

1. Installation of interconnecting piping

- When mating interconnecting fittings to the filter unit make sure that filter components are securely held in place so no damage or leaks occur.
- If welding or soldering mating flanges or fittings make sure not to overheat filter components. Overheating filter components can cause damage or leaks.
- If welding DO NOT use the filter or its components as a ground.

2. Refer to Table II for piping connection sizes.

NOTE: It is important that all piping and components associated with the filter system installation must be supported to eliminate stress on the filter and piping.

NOTE: Do Not reduce the pipe sizes listed, the pipe sizes are minimums. If long runs, excess fittings, or lifts are necessary, it is recommended to enlarge the pipe diameter in order to reduce friction loss. Never reduce the waste line; this can restrict the flow of the backwash cycle and reduce efficiency.

3. Run an influent line from the system sump to the pump pre-strainer labeled "INLET". A service valve and union should be installed in this line near the filter. Refer to specification drawings.

NOTE: If the filter inlet connection is located above the process liquid operating level, a foot or check valve must be installed below the water level to prevent loss of pump prime.

4. Run an effluent line from the filter return labeled "OUTLET" back to the system sump. A service valve and union should be installed in this line near the filter. Refer to specification drawings.

5. Run a waste line from the filter waste outlet labeled "WASTE" to the nearest sewer drain. Table III on page 7 lists the minimum and maximum backwash flow rates and volumes for the PF-20 series. A union should be installed in this line near the filter. Refer to specification drawings.

NOTE: Do not put any type of valve in the waste line! The sewer drain must be large enough to handle and maintain the flow of the backwash cycle. If the drain is not large enough to support the volume of waste generated during a backwash cycle, it may be necessary to use a reservoir tank to collect the waste water. The flow from the reservoir tank can then be regulated to the drain.

6. For filters utilizing a source other than the process system water for backwash supply, Table III shows the required backwash flow and volumes. The maximum backwash supply pressure for the PF-20 filter is 40 psi. Run a line to the connection labeled "BACKWASH." If public or municipal water is used for backwash, a backflow preventer is required in this line on all units. A service valve and union should be installed in this line near the filter.

NOTE: Never overtighten service unions on the filter unit. Service unions should be hand tightened only. Overtightening can cause damage, which may result in leaks.

NOTE: Always follow local, county, state or other government authorities requirements for piping hook-ups.

**TABLE II - PIPING CONNECTION SIZES - DIMENSIONS SHOWN IN INCHES**

| MODEL - PF20 | INLET      | OUTLET    | WASTE     | BACKWASH  |
|--------------|------------|-----------|-----------|-----------|
| 12           | 1 1/2 FLNG | 1 FPT     | 1 FPT     | 1 FPT     |
| 18           | 1 1/2 FLNG | 1 1/2 FPT | 1 1/2 FPT | 1 1/2 FPT |
| 24           | 1 1/2 FLNG | 1 1/2 FPT | 1 1/2 FPT | 1 1/2 FPT |
| 30           | 2 FLNG     | 2 FPT     | 2 FPT     | 2 FPT     |
| 36           | 2 1/2 FLNG | 2 1/2 FPT | 2 1/2 FPT | 2 1/2 FPT |
| 42           | 3 FLNG     | 3 FLNG    | 3 FLNG    | 3 FLNG    |
| 48           | 4 FLNG     | 4 FLNG    | 4 FLNG    | 4 FLNG    |

| <b>TABLE III - FLOW RATES - FLOWS SHOWN IN GALLONS/MINUTE</b> |                    |                  |                  |                   |
|---|--------------------|------------------|------------------|-------------------|
| <b>MODEL - PF20</b>   | <b>FILTER RATE</b> | <b>B/W (MAX)</b> | <b>B/W (MIN)</b> | <b>B/W VOLUME</b> |
| 12  | 15                 | 15               | 12               | 45 GAL            |
| 18  | 35                 | 35               | 30               | 105 GAL           |
| 24  | 65                 | 65               | 55               | 195 GAL           |
| 30  | 100                | 100              | 85               | 300 GAL           |
| 36  | 140                | 140              | 120              | 420 GAL           |
| 42  | 190                | 190              | 162              | 570 GAL           |
| 42  | 250                | 250              | 214              | 750 GAL           |

\* Backwash duration is factory set for 3 minutes.

## LOADING MEDIA

The filter media should be installed as follows (refer to Table IV for media quantities).  
One Drum = 1/2 cubic foot.

The 20 series filter units are supplied with two types of media (support gravel and filter media). The support gravel is used at the base of the filter below the underdrain to support the filter media. The filter media is a spherical based crystalline silica and will remove up to 90% by volume of the suspended solids 10 microns and larger. The filter media will be shipped in 1/2 cubic-foot drums.

1. To load the filter media in the PF-20 series filter, remove the hex nut and crab clamp from the handhole/manhole ring (be careful not to drop the handhole/manhole into the vessel). Press down on the handhole/manhole cover until it drops loose. Remove the gasket and rotate the handhole cover lifting it through the tank ring. Inspect the internals for damage before continuing.
2. Fill the vessel with water until the underdrain assembly is completely submerged in water. Load the support gravel into the filter vessel first and level it out, then load the 10 micron silica into the vessel and level it out (refer to Table IV for the amount of media required for each individual PF-20 series filter).
3. Inspect the handhole/manhole, gasket, ring, and cover for foreign matter, and clean all surfaces. Place the handhole/manhole cover into the vessel. Slip the gasket over the handhole/manhole and reinstall the crab clamp and hex nut. Align the gasket and crab clamp properly with the handhole/manhole and ring, before tightening the hex nut. Do not overtighten the hex nut. Overtightening the hex nut can damage the gasket.
4. Always follow start-up procedures whenever the filter unit has been turned off.

| <b>TABLE IV - MEDIA REQUIREMENTS</b> |                        |                     |
|--------------------------------------|------------------------|---------------------|
| QUANTITIES SHOWN IN 1/2 CU.FT.       |                        |                     |
| <b>MODEL - PF20</b>                  | <b>SUPPORT MEDIA</b>   | <b>FILTER MEDIA</b> |
| 12                                   | 1                      | 1                   |
| 18                                   | 2                      | 2                   |
| 24                                   | 3                      | 5                   |
| 30                                   | 4                      | 5                   |
| 36                                   | 7                      | 10                  |
| 42                                   | 14                     | 13                  |
| 48                                   | <b>Consult Factory</b> |                     |

\* Media quantities depend on vessel construction.

## ELECTRICAL CONTROLS

The PF-20 series filter can be supplied in a number of configurations and voltages. Standard voltages include 460v/3Ø/60hz, 230v/3Ø/60hz, 208v/3Ø/60hz (additional alternate voltages are available). Primary voltage will be reduced to 120v control voltage. Control components will vary depending on filter configuration and options.

1. Standard filter units supplied with automatic backwash are equipped with a NEMA type 4X control cabinet containing a locking combination on/off disconnect switch with motor circuit protection (MCP), control transformer (primary/120v secondary), adjustable backwash timer, 24 hour backwash time clock, magnetic motor starter (external backwash source units only), pressure differential switch, electric valve actuator, terminal strip and manual override push button.

NOTE: A NEMA type 3R coated steel enclosure may be supplied as an alternative to the NEMA type 4X polycarbonate enclosure on certain units.

NOTE: Optional control items may include: programmable logic controller (PLC), indicating lamps, delay timer, audio and visual alarms, dry contact signals, and hand-off-auto (HOA) switch.

2. Manual filter units are provided with a manually controlled valve positioner and exclude all control components and motor protection.



## WIRING REQUIREMENTS

### Manual Units:

1. Install a circuit breaker between the closest branch distribution panel and the pump motor (refer to Table V for amperage draw by motor horsepower).
2. Install an externally operated switch with fuse protection and door interlock in plain sight of the filter. Fuse protection must be sized to handle starting and full load amperage draws.

### Automatic Units:

1. Install circuit breaker between the closest branch distribution panel and the control panel (refer to Table V for amperage draw by motor horsepower). The control cabinet is pre-wired and includes a door disconnect switch with overload and short circuit protection.

NOTE: Always follow local, county, state or other government authorities requirements for electrical hook-up.

NOTE: All incoming power supply lines must be connected to the door disconnect.

| TABLE V - ELECTRICAL REQUIREMENTS |               |                  |
|-----------------------------------|---------------|------------------|
| MOTOR HP                          | MOTOR VOLTAGE | AMPERAGE 1 PHASE |
| 1                                 | 110, 208, 220 | 16, 9, 8         |
| 2                                 | 110, 208, 220 | 24, 14, 12       |
| MOTOR HP                          | MOTOR VOLTAGE | AMPERAGE 3 PHASE |
| 1                                 | 208, 240, 460 | 5, 4, 2          |
| 2                                 | 208, 240, 460 | 8, 7, 4          |
| 3                                 | 208, 240, 460 | 11, 10, 5        |
| 5                                 | 208, 240, 460 | 17, 16, 8        |
| 7 1/2                             | 208, 240, 460 | 25, 22, 11       |

## SECTION 2

### THEORY OF OPERATION

Influent (unfiltered) fluid is drawn via the pump into the filter piping, where it enters the overdrain (upper internals). The influent fluid is dispersed over the filter media evenly. Suspended solids are trapped in the pores formed between the media. The effluent (filtered) fluid then passes from the vessel through the underdrain (lower internals) and is returned to the system.

The differential pressure increases as the trapped particles load the media. When the differential pressure reaches 16 psi, a backwash cycle is required. The control valves are repositioned, reversing the flow and the media is backwashed. The reverse flow lifts and churns the media causing a scouring action to release the trapped debris. The trapped debris is then pushed up through the overdrain and flushed to drain. On completion of the backwash cycle, the valves are repositioned and the filtration process continues.

### OPERATION AND MAINTENANCE

The following information pertains to the procedures, operation and general maintenance of the PF-20 series permanent media filter.

Please read this entire OPERATION and MAINTENANCE MANUAL thoroughly and understand all safety related issues before attempting any work on the PF-20 series filters.

### GENERAL MAINTENANCE PROCEDURES

Always follow the start-up and shut down procedures before and after any service or maintenance is done on the filter unit. The PF-20 series filters are designed for low maintenance and minimal service. With proper care the PF-20 series filters will provide trouble free service. The following is a list of maintenance check points and schedules.

NOTE: All recommendations are minimums. The environment/operating conditions in which the filter unit is installed will dictate the frequency of scheduled maintenance. Maintaining your PF-20 Series filter will assure a long trouble free life.

1. Visually inspect filter every 48 hours (minimum) for proper operation (check for unusual noise and/or vibration).
2. Read pressure gauge (gauge reading should not exceed 75 psi).
3. Backwash filter every 48 hours (minimum).
4. Never allow differential pressure to increase above 16 psid.
5. Check media condition every 6 months (replace if needed).
6. Inspect filter internal assembly each media change.
7. Clean pump pre-strainer before blind-off occurs (check as often as environment dictates).
8. Check condition of gaskets (filter and pre-strainer) each time the filter is serviced.
9. Check voltage and amperage draw on motor lead.

## SETTING 24 HOUR TIME CLOCK

Figure 2

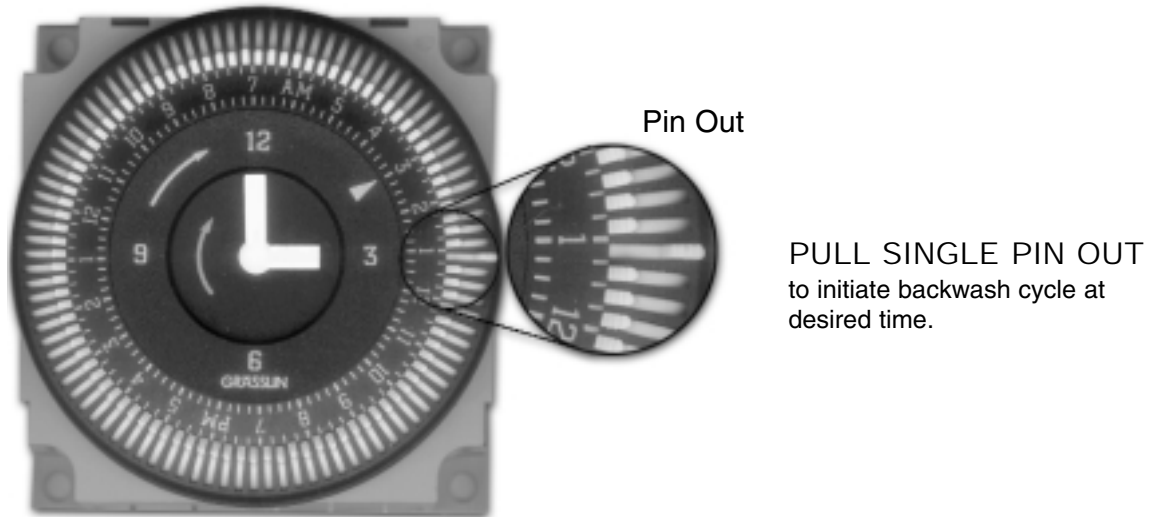

The 24 hour time clock initiates a backwash cycle at any specified time in the day. The backwash clock comes preset from the factory for a backwash cycle to occur once every 24 hours of run time (refer to Figure 2).

By moving the pins (in or out) on the 24 hour time clock, the number of backwash cycles in a 24 hour period can be adjusted. Every pin represents 15 minutes of a 24 hour period. For every non-consecutive pin pulled out in a 24 hour period, the filter will backwash. The time clock can only initiate a backwash once every 1/2 hour. Pins pulled out consecutively will initiate a backwash once and then lock out any further backwash cycle 15 minutes for each consecutive pin pulled out. In order to eliminate the 24 hour time clock from initiating a backwash cycle, move all pins in toward the center.

**NOTE:** The 24 hour time clock is a non-resetting clock.

**NOTE:** The 7-day timer works in the same manner as the 24 hour time clock except each pin represents 2 hours.

**NOTE:** If a Programmable Logic Controller (PLC) is supplied, a 48 hour clock has been programmed into the PLC. The automatic backwash cycle is initiated every 48 hours of run time (minimum). Every initiation of the backwash cycle, whether initiated manually or automatically, will reset the 48 hour clock.

## PUMP PRE-STRAINER

For a diagram of the pump pre-strainer refer to Figure 3 on page 18. The pump pre-strainer housing is flanged mounted to the pump suction. The pre-strainer contains a corrosion resistant stainless steel basket with 1/8 inch perforations. The pre-strainer basket must be kept clean and free of debris. Always follow the shut down procedure before attempting any repairs, adjustments or cleaning. To clean the pre-strainer basket loosen the four hex bolts that hold the cover in place. Gently lift the cover off the strainer body (take care not to damage the gasket). If the gasket does not come off in one piece it will need to be replaced. Before replacing gasket clean all surfaces of old material. Utilize the handle to remove the basket from the housing. After cleaning the basket reverse the above procedure making sure that the gasket is in place and tighten the four hex bolts. Always follow the start-up procedures after any shut-down (refer to page 14).

**NOTE:** Always relieve internal vessel pressure before attempting any repairs or adjustments on the filter unit.

## PUMP AND MOTOR

The pump wet end is cast iron bronze fitted. The close coupled, back pull-out pump and motor assembly is bolted together with hex bolts for ease of maintenance or repair. The pump utilizes a standard mechanical seal pressed into the motor bracket, which is bolted directly to the pump volute. The pump sleeve slides over the motor shaft. The pump impeller is threaded or keyed on to the end of the motor shaft and locked in place with a hex jam nut (for a diagram refer to Figure 3 on page 18).

The pump flows for the PF-20 series filters are listed in Table III on page 7 at 50 feet of head (TDH). This correlates to approximately 22 psi discharge pressure at design flow.

**WARNING:** Disconnect and lock out all electrical power to the filter prior to performing pump maintenance.

## CLEANING & ADJUSTING PUMP

Always follow the shut down procedure before attempting any repairs or adjustments. The impeller should spin freely. If not, check for an obstruction or debris that may be lodged between the impeller and volute or impeller and adapter bracket. If no debris can be found and the impeller remains obstructed remove the bolts holding the volute to the motor bracket and the two bolts holding the motor to the base (refer to Figure 3 on page 18). Slide the motor and motor bracket away from the pump volute. Inspect the volute for foreign material. Reverse the above procedures to reassemble (replace any gaskets which are not in good condition). Rotate the pump shaft manually after assembly to check clearance. Always follow the start-up procedures whenever the filter unit has been turned off.

## FILTER VESSEL

The filter vessel is constructed of stainless steel with coated carbon steel handholes/manholes. The vessel is designed with a handhole/manhole located in the upper head for service. The internals are constructed of corrosion resistance Sch 80 PVC plastic. The underdrain assembly is a header lateral configuration designed to help induce even flow through the media. The underdrain laterals can be removed individually by rotating each lateral counter clockwise until all threads are disengaged. The 3 point overdrain assembly is designed to distribute the influent evenly over the top of the filter media. The internal assembly should be thoroughly inspected before adding media. To inspect the internals follow the shut down procedure. Carefully remove the filter vessel handhole by removing the hex nut on the crab clamp of the filter vessel (do not drop the handhole into the filter vessel). Refer to Loading Media on page 7.

NOTE: Always relieve internal vessel pressure before attempting any repairs or adjustments on the filter unit.

## BACKWASH CYCLE

When the pressure drop across the media bed reaches its terminal differential pressure (16 psid), it is necessary to initiate a backwash. The backwash cycle must be completed in order to keep the media from becoming contaminated. Higher differential pressures drive the debris deep into the media bed where they cannot be flushed out. Over a period of time, the buildup of debris will cause a media failure and channeling or plugging of the media will occur.

### Automatic Units

Controls are furnished with a factory preset pressure differential switch, manual backwash override push button and a 24 hour time clock to activate a backwash cycle. Upon an initiation of a backwash cycle the electric valve actuator will reposition the valves into the backwash mode. The backwash cycle is preset from the factory for three minutes. After completion of the backwash cycle the electric valve actuator will reposition the valves into the filter mode. The duration of the backwash time may be adjusted if necessary. Please consult the factory before adjusting the backwash timer. It is essential that the backwash time remain at a minimum of three minutes to insure that the media is cleaned properly.

### Manual Units

The manual units function in the same manner as the automatic units except the valves have to be manually repositioned into and out of the backwash cycle. The filter unit will need a backwash cycle when the differential pressure reaches 16 psid or a minimum of every 48 hours. The operator must shut off the pump before repositioning the valves into or out of the backwash cycle. For filter units utilizing the system for a backwash supply, reposition the valves, and then turn the pump back on. The backwash cycle should run three minutes. After completing a backwash cycle, the pump should be turned off and the valves repositioned to the filter cycle. Once the valves are repositioned, the pump can be turned back on. For filter units utilizing an external source for a backwash supply, the pump must remain off during the three minute backwash cycle. After three minutes, the valves are repositioned into the filter position and the pump can be turned back on.

NOTE: Always relieve any trapped air in the filter vessel.

## START-UP PROCEDURE

Before initial start-up or after a long shutdown period, the filter unit should be thoroughly inspected.

**NOTE:** Perform the first five recommendations with the electrical power off and locked out. Refer to the section under "Safety" regarding the safeguarding of maintenance personnel from biological contaminants prior to start-up.

1. Close all isolation valves in interconnecting piping and relieve all pressure from the filter system by opening the manual air relief valve.
2. Loosen the four hex bolts around the pump pre-strainer lid. Remove the lid, inspect gasket and lubricate if necessary. Clean debris from the pump pre-strainer basket. Prime the pump and associated piping by filling the pre-strainer housing. Replace the basket and lid then tighten bolts.
3. Turn the pump and motor shaft by hand to insure free rotation.
4. Remove the top handhole/manhole cover by removing the hex nut on the crab clamp by pushing the handhole/manhole into the vessel (do not drop handhole/manhole). Remove and inspect the gasket (replace if necessary).
5. Inspect the internal assembly for any damage. Install media as described in Loading Media on page 7.
6. Inspect the handhole/manhole, gasket, ring, and cover for foreign matter, and clean all surfaces. Place the handhole/manhole cover into the vessel. Slip the gasket over the handhole/manhole and reinstall the crab clamp and hex nut. Align the gasket and crab clamp properly with the handhole/manhole and ring, before tightening the hex nut. Do not overtighten the hex nut. Overtightening the hex nut can damage the gasket.
7. Prime pump by filling the pre-strainer and associated piping with water (refer to pump pre-strainer on page 12). Check pump rotation by bumping the motor. Verify rotation with the arrow on the pump volute. **DO NOT** run the pump for an extended period of time in reverse direction or dry. Have a qualified electrician change leads to correct rotation.
8. Open the service valves in the filter inlet, outlet, and backwash lines. Before starting the pump verify all valves are open. Open the manual air relief valve on top of the filter vessel. Start the pump and fill the filter vessel. Once a steady stream of water is coming out of the manual air relief valve, and all air has been evacuated, the manual air relief valve can be closed. Verify the auto air vent is open by turning the knob located on the top of the unit one half turn.
9. Check the voltage and current of all leads on the pump motor. The correct amperage draw can be found on the motor nameplate (refer to Table 5 on page 9).
10. Check the filter unit for any unusual noise or vibration. Shut filter unit off and contact your local PUROFLUX representative or the factory direct if there are any questions about the performance of the filter unit.
11. Check the filter unit and all integral piping to the unit for any air or fluid leaks. All air leaks must be found and repaired. Failure to do so could result in poor performance and/or personal injury.
12. Backwash the filter (refer to Backwash Cycle on page 13 and Table III on page 7). After backwashing the filter, check the pressure gauge on top of the filter vessel and record the clean start up pressure. Use the starting pressure as a bench mark whenever routine maintenance is performed.
13. After several hours of run time from start up, perform steps 8 through 12 again.

**NOTE:** An excessive amount of air released from the vent valve can indicate an air leak. All leaks must be repaired before running the filter unit.

## OPERATION IN COLD WEATHER

When the PF-20 series filter is exposed to below-freezing temperatures, it will require protection to prevent freezing. An indoor installation in a heated room is the best way to prevent freezing of any liquid in the filter unit. If an indoor installation is not practical, supplemental heat must be supplied. Heat tape and insulation around the liquid filled filter components must be used to prevent freezing. The filter unit should be drained when not in use for long periods of time. Refer to shutdown procedures below.

## SHUTDOWN

The following services should be performed when the unit is to be shutdown for a prolonged time period.

1. Run the filter unit through a complete backwash cycle.
2. Shut off and lock out all electrical power.
3. Close the service valves in the filter inlet, outlet and backwash lines.
4. Relieve all pressure from the filter vessel and piping. Open the manual relief valve located on top of the vessel and leave the valve open.
5. Drain all external piping to and from the filter.
6. Remove the drain plug on the filter vessel. Allow the liquid to drain. After all liquid has drained replace the drain plug. Open the drain plug on the pre-strainer housing. Allow all the liquid to drain and then replace the drain plug.
7. Remove the bolts from the pump pre-strainer cover. Remove the cover and clean debris from the pump pre-strainer basket. Inspect the gasket and lubricate (replace gasket if necessary). Replace the basket and cover and tighten bolts.
8. Remove the top handhole/manhole cover by removing the hex nut on the crab clamp by pushing the handhole/manhole into the vessel (do not drop handhole/manhole). Remove and inspect the gasket (replace if necessary).
9. Inspect the media for foreign material. Over a period of time, a build up of debris may become imbedded in the media which cannot be backwashed out. Contaminated media should be discarded. If the media pack is contaminated, replace the media. If the media is removed, thoroughly inspect the internal assembly before loading new media (refer to Loading Media and Table IV on page 7). Reinstall the handhole/manhole cover.
10. Close the manual air relief valve located on the top of the vessel.

## RECOMMENDED SPARE PARTS

PUROFLUX maintains a complete stock of replacement parts. When ordering replacement or stock parts, be sure to include the unit serial and model numbers.

The following spare parts are recommended:

1. Gaskets for filter vessel handhole/manhole.
2. Pre-strainer gasket.
3. Replacement media.
4. Pump seal and gasket kit.
5. Transformer fuses (automatic units only).

## FLUID TREATMENT

Filtration is an effective way of reducing the level of suspended solids in a system. However, it is only one portion of a complete treatment program. Dissolved solids will not be removed from the system by media filtration. It is important to realize that the dissolved solids will concentrate, and can cause damage to a system. Furthermore, airborne impurities and biological contaminants may be introduced into the system through the equipment being filtered.

To control all potential contaminants, a chemical treatment program must be employed by a competent professional. Such treatment should be initiated before the system start-up and continued regularly thereafter.

## SAFETY

All electrical, mechanical, and rotating machinery are potential hazards. It is important to be familiar with the design, construction, and operation of all equipment before performing any work. Always use adequate safeguards (including use of protective clothing where necessary or required) whenever installing, operating, or working on the equipment.

Care should be taken when working on, near, or around this equipment. Appropriate safeguards must be established to prevent personnel and/or public from injury and to prevent damage to the equipment, affiliated system, and premises.

It is important to be thoroughly familiar with the equipment, associated system, controls, and the procedures set forth in this manual. Only qualified personnel should operate, maintain, and repair this equipment. Always follow proper procedures and use the correct tools, when handling, lifting, installing, operating, maintaining, or repairing the equipment. This will aid in the prevention of personal injury and/or property damage.



## SECTION 3

### WARRANTY

PUROFLUX will guarantee all products to be free from manufactured defects in materials and workmanship for a period of 12 months from the date of shipment. In the event of any such defect, PUROFLUX will repair or provide a replacement. **NOTE:** Pump seals are **NOT** covered under standard warranty.

NOTE: Replacement part(s) may be new or remanufactured, at Puroflux's option. All warranty products, which prove to be defective will be shipped F.O.B. Puroflux's plant. Puroflux will not replace, repair or pay for any charges without a written agreement prior to such work.

This warranty is not extended to any defects that can be attributed to having been caused by accident, alteration, abuse, misuse, consumer negligence, normal expected wear, chemical corrosion or outside influences.

To obtain any needed repair(s) or replacement of defective parts or product, a Return Goods Authorization (RGA) number must first be obtained from PUROFLUX. This will be the record for tracking all items returned to PUROFLUX. The RGA form must be returned with the defective items in order to insure proper credit.

Before the replacement part can be sent a purchase order must be issued to cover the cost of each replacement part and shipping. Upon inspection and an issue of credit of the defective items by PUROFLUX and/or PUROFLUX'S vendor(s), credit will be issued.

NOTE: Items deemed defective will be replaced with a new or remanufactured part (at PUROFLUX'S option). This includes both mechanical and electrical components.

NOTE: Shipping and handling, labor, or repair charges are not covered by PUROFLUX'S warranty policy.

NOTE: The return of defective items must be made within thirty (30) days of shipment or the invoice will be considered due and payable.

NOTE: Any damage to the filter unit during shipment must be claimed at the time of accepting the filter (note all damage to the filter unit on the bill of lading before signing). All damages received during shipping are the sole responsibility of the freight company and must be taken care of through the freight company.

FIGURE 3

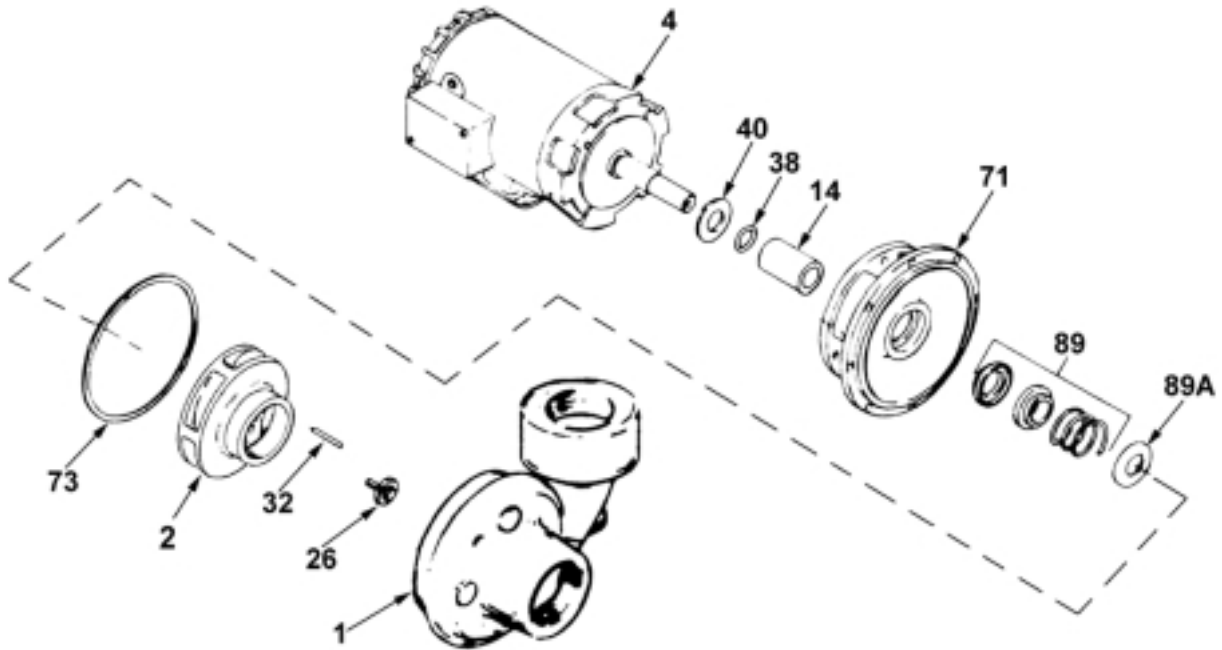

| ITEM | DESCRIPTION       |
|------|-------------------|
| 1    | Case              |
| 2    | Impeller          |
| 4    | Motor             |
| 14   | Shaft Sleeve      |
| 26   | Impeller Retainer |
| 32   | Key               |
| 38   | O-Ring, Shaft     |
| 40   | Flinger           |
| 71   | Adapter, Iron     |
| 73   | Gasket, Case      |
| 89   | Seal              |
| 89A  | Seal Retainer     |