

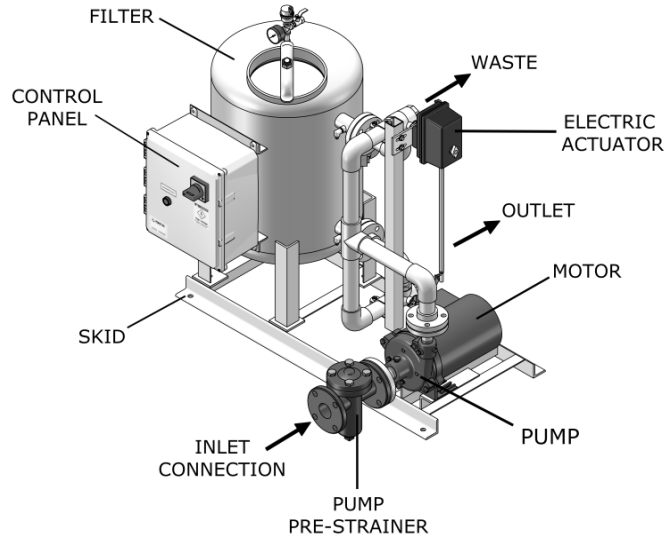

ENGINEERING • MANUFACTURING • SERVICE

## PF-2018-02-01 SPECIFICATION SHEET PUMP PACKAGE SYSTEM



### Features:

- Removes particulate as low as 10 microns
- 75 psi working pressure
- Fully assembled skid package
- One year limited warranty

### Options:

- Higher pressure ratings
- ASME code stamped vessel

## SYSTEM COMPONENTS

SPECIFICATIONS	PF-2018-02-01
Flow Rate	35 GPM
Filtration Area	1.77 sq ft
Valve Size	1 1/2"
System Inlet Connection	2" Flg
System Outlet Connection	1 1/2" fpt
Waste Connection	1 1/2" fpt
Backwash Connection	N/A
Pump Motor	1.5 HP
Est. Weight, Dry	570 lbs
Est. Weight, Operating	730 lbs

### Filter Vessel :

- Non-code stainless steel vessel
- Epoxy coated carbon steel hand hole covers
- Pressure gauge & manual air vent valves
- Industrial grade 3-way ball valves

### Electrical Controls :

- UL labeled control panel with NEMA 4X Enclosure
- Adjustable solid state timer
- Short circuit and Motor overload protection
- Electric actuator

### Pump :

- Close coupled, end suction centrifugal pump
- TEFC motor
- Cast iron pre-strainer with removable SST basket

### Backwash Controls :

- Pressure differential switch
- 24 Hour time clock
- Manual push button

### Skid :

- Fusion-bond polyester coated carbon steel

### Interconnecting Pipe :

- Sch.80 PVC piping

\*Shipping weight includes media

NOTES: UNLESS OTHERWISE SPECIFIED

1. DIMENSIONS ARE IN INCHES
2. DIMENSIONS MAY VARY SLIGHTLY - DO NOT USE FOR CONSTRUCTION
3. FILTER SYSTEM RATED @ 75 PSI (WORKING)

REVISIONS			
REV	DESCRIPTION	DATE	APPROVED
A	REVISED PUMP BRACKETS	2-19-14	D.L.

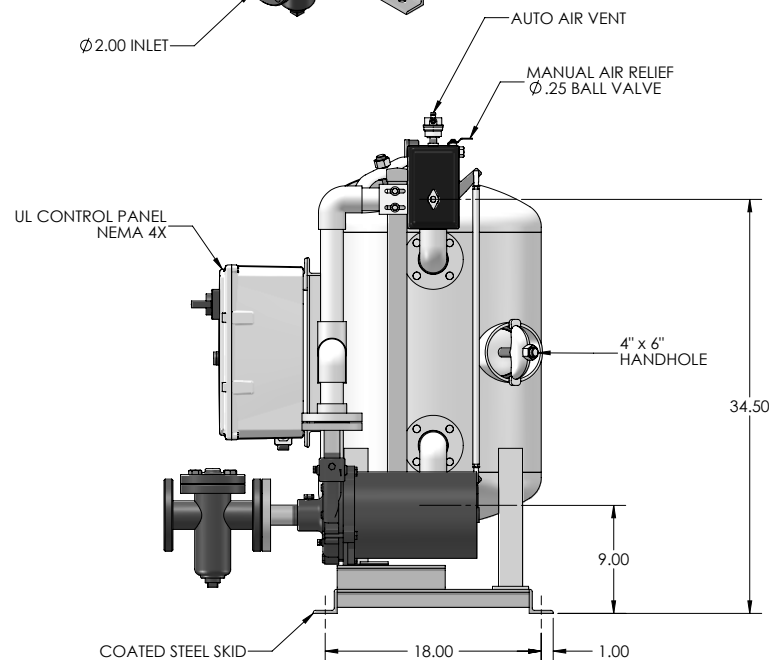
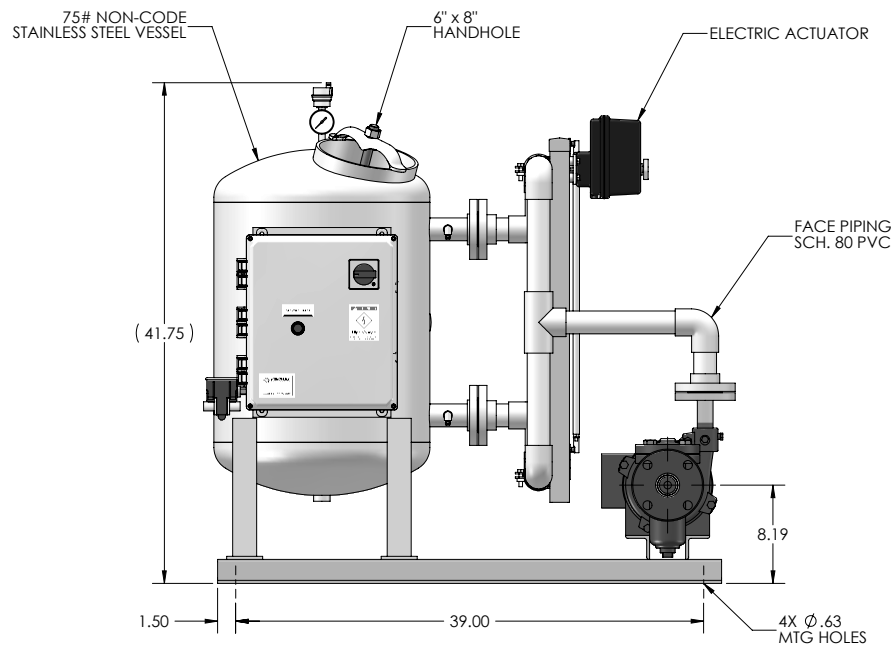
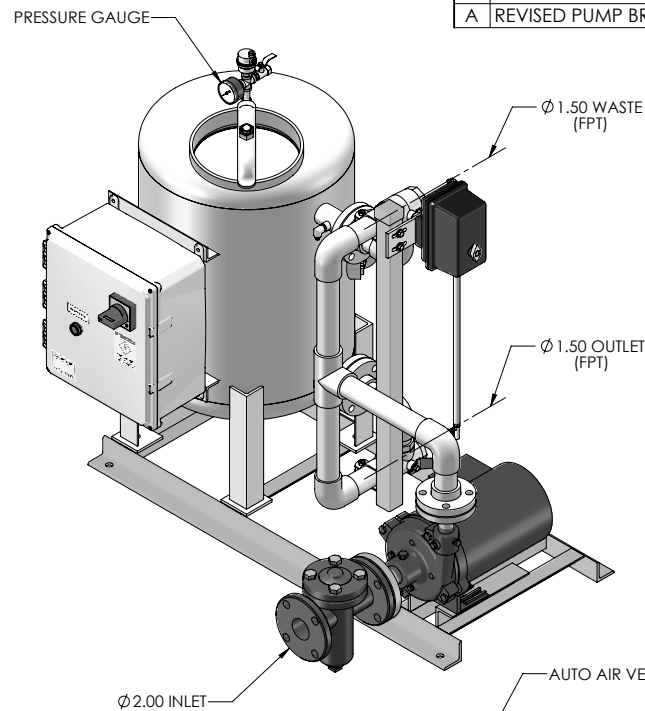
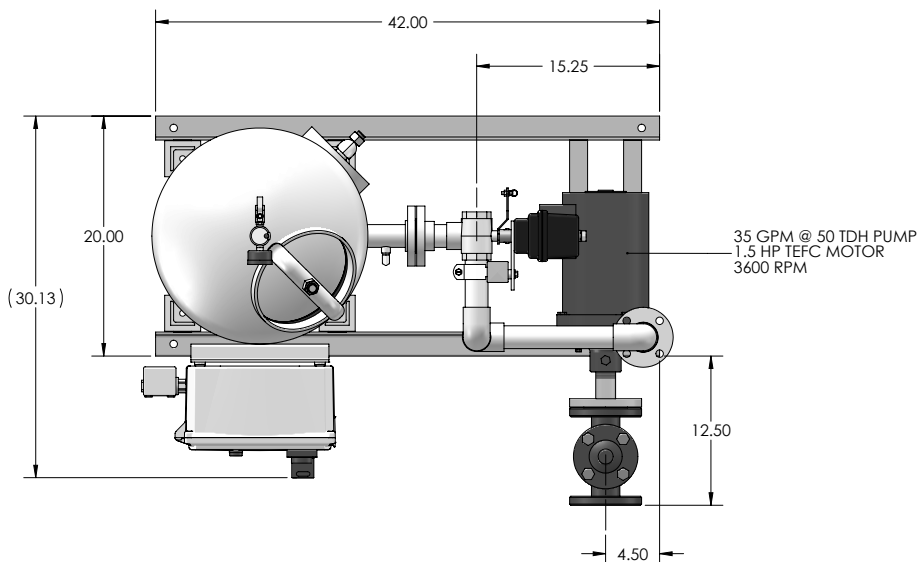

PROPRIETARY AND CONFIDENTIAL THE INFORMATION CONTAINED IN THIS DRAWING IS THE SOLE PROPERTY OF PUROFLUX CORPORATION. ANY REPRODUCTION IN PART OR AS A WHOLE WITHOUT THE WRITTEN PERMISSION OF PUROFLUX CORPORATION IS PROHIBITED.	PF-2018-02-01-UL: FILTER SYSTEM SOURCE WATER BACKWASH		REV A
	SIZE C DWG NO. 201-0124	RELEASE DATE 2-22-13	
DRAWN D. LUNA	WWW.PUROFLUX.COM		SHEET 1 OF 1



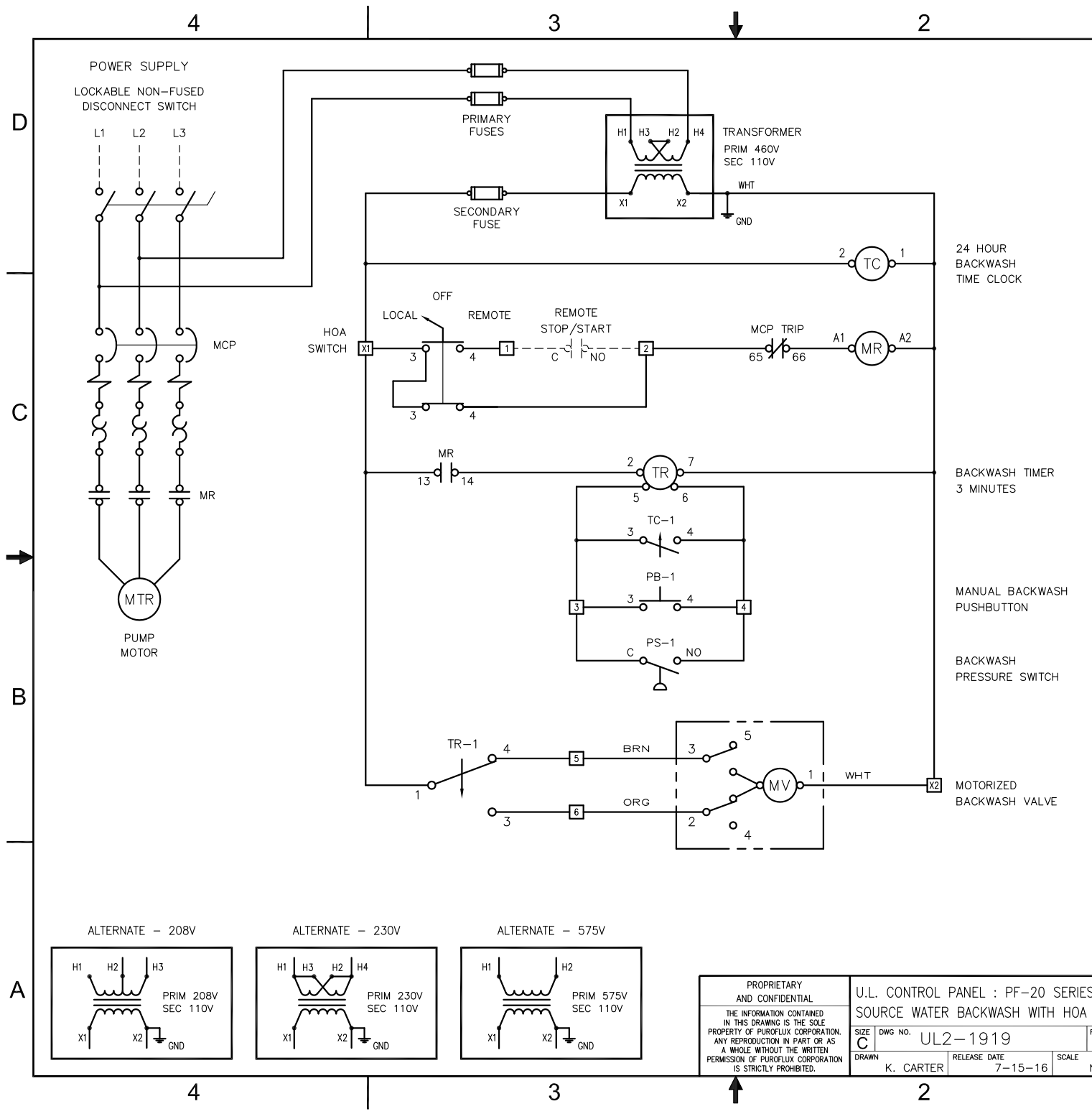

REVISIONS			
REV	DESCRIPTION	DATE	APPROVED

PUMP MOTOR FULL LOAD AMPS ( 3Ø, 60Hz )				
MOTOR HP	208 VOLTS	230 VOLTS	460 VOLTS	575 VOLTS
1	3.22	2.8	1.4	1.12
1.5	5.01	4.36	2.18	1.94
2	6.44	5.6	2.8	2.24
3	9.59	8.34	4.17	3.34
5	15.5	13.5	5.76	5.41

FULL LOAD CURRENTS LISTED ABOVE ARE "AVERAGE VALUES" FOR HORSEPOWER RATED MOTORS OF SEVERAL MANUFACTURERS. THE RATED FULL LOAD CURRENT SHOWN ON THE MOTOR NAMEPLATE MAY VARY BY MANUFACTURER.

- NOTES**
- NOTES: UNLESS OTHERWISE SPECIFIED
- BRANCH CIRCUIT PROTECTION SUPPLIED BY OTHERS
  - PANEL U.L. LISTED AND LABELED
  - DASHED LINES INDICATE FIELD WIRING
  - SWITCH OPERATION  
 "LOCAL" - REMOTE STOP/START OVERRIDE  
 "OFF" - FILTER "OFF"  
 "AUTO" - FILTER ON/OFF VIA REMOTE STOP/STOP

**WARNING**

If an overload or fault current interruption occurs, circuits must be checked to determine the cause of the interruption. If a fault condition exists, the current carrying components should be examined and replaced if damaged, and the integral current sensors must be replaced to reduce the risk of fire or electric shock.

**CAUTION - RISK OF ELECTRICAL SHOCK**

More than one disconnect switch may be required to de-energize the equipment before servicing.

**WARNING - RISK OF FIRE OR ELECTRIC SHOCK**

The opening of the branch circuit protective device may be an indication that a fault current has been interrupted. All current carrying parts and other components protected by this device should be examined and replaced if damaged. If burnout of a current element of an overload relay occurs, the complete overload relay must be replaced.

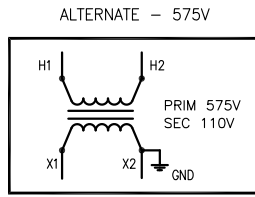
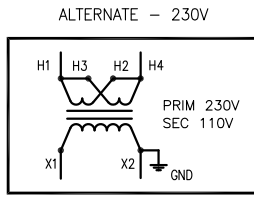
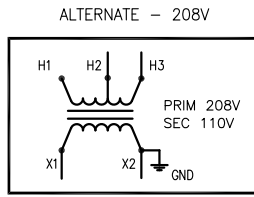

PROPRIETARY AND CONFIDENTIAL

THE INFORMATION CONTAINED IN THIS DRAWING IS THE SOLE PROPERTY OF PUROFLUX CORPORATION. ANY REPRODUCTION IN PART OR AS A WHOLE WITHOUT THE WRITTEN PERMISSION OF PUROFLUX CORPORATION IS STRICTLY PROHIBITED.

U.L. CONTROL PANEL : PF-20 SERIES  
SOURCE WATER BACKWASH WITH HOA

SIZE C DWG NO. UL2-1919 REV -

DRAWN K. CARTER RELEASE DATE 7-15-16 SCALE NONE

**PUROFLUX CORPORATION**

WWW.PUROFLUX.COM SHEET 1 OF 1