

PF-63-025 SPECIFICATION SHEET PUMP PACKAGE SYSTEM

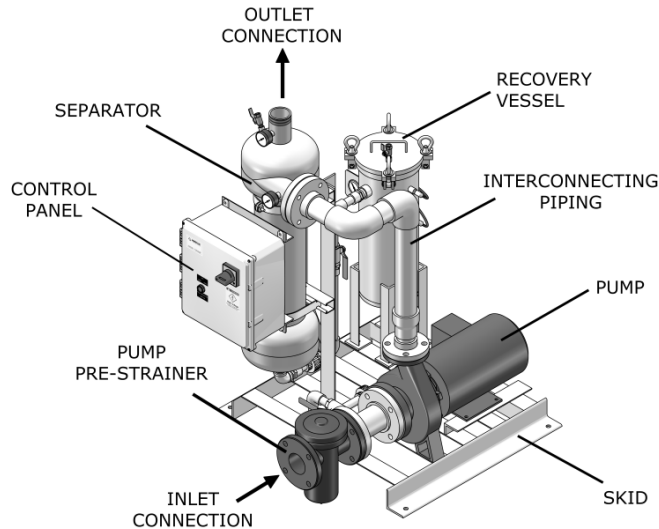

Features:

- Removes particulate as low as 45 microns
- 150 psi working pressure
- Fully assembled skid package
- One year limited warranty

Options:

- Removable dome separator
- 22 1/2° Profile separator
- Coated carbon steel piping
- Isolation valve kit
- Dry contact for alarm

SYSTEM COMPONENTS

SPECIFICATIONS	PF-63-025
Flow Rate	160 GPM
System Inlet Connection	3" Flg
System Outlet Connection	2 1/2" mpt
Recovery Vessel Model	PF-RV-1S
Separator Model	PF-61-025
Separator Purge	Continuous
Pump Motor	5 HP
Volume	14 GAL
Est. Weight, Dry	640 lbs
Est. Weight, Operating	752 lbs

Separator :

- PF-61 Series separator
- Fusion-bond polyester coated vessel
- Manual air bleed valve
- Inlet/Outlet pressure gauges

Electrical Controls :

- UL labeled control panel with NEMA 4X Enclosure
- Door disconnect switch
- Short circuit and Motor overload protection
- Hand-Off-Auto switches

Pump :

- Centrifugal pump
- TEFC motor
- Cast iron pre-strainer

Recovery Vessel :

- 304 Stainless steel vessel
- Pressure differential indicator
- Automatic flow controller

Skid :

- Fusion-bond polyester coated carbon steel

Interconnecting Pipe :

- Sch.80 PVC piping

NOTES: UNLESS OTHERWISE SPECIFIED

1. DIMENSIONS ARE IN INCHES
2. DIMENSIONS MAY VARY SLIGHTLY - DO NOT USE FOR CONSTRUCTION
3. SEPARATOR SYSTEM IS RATED FOR 150 PSI WORKING PRESSURE

REVISIONS			
REV	DESCRIPTION	DATE	APPROVED
-			

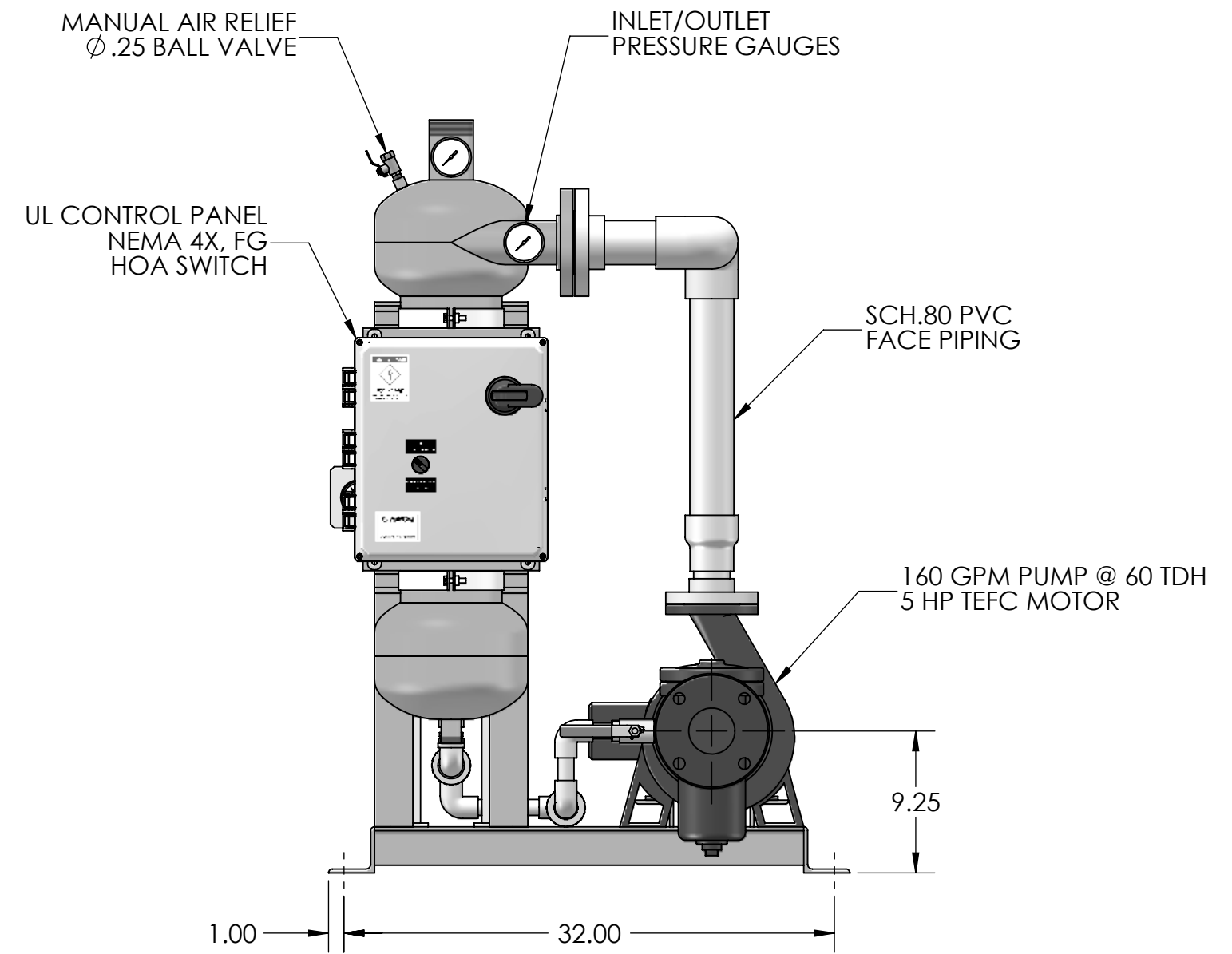
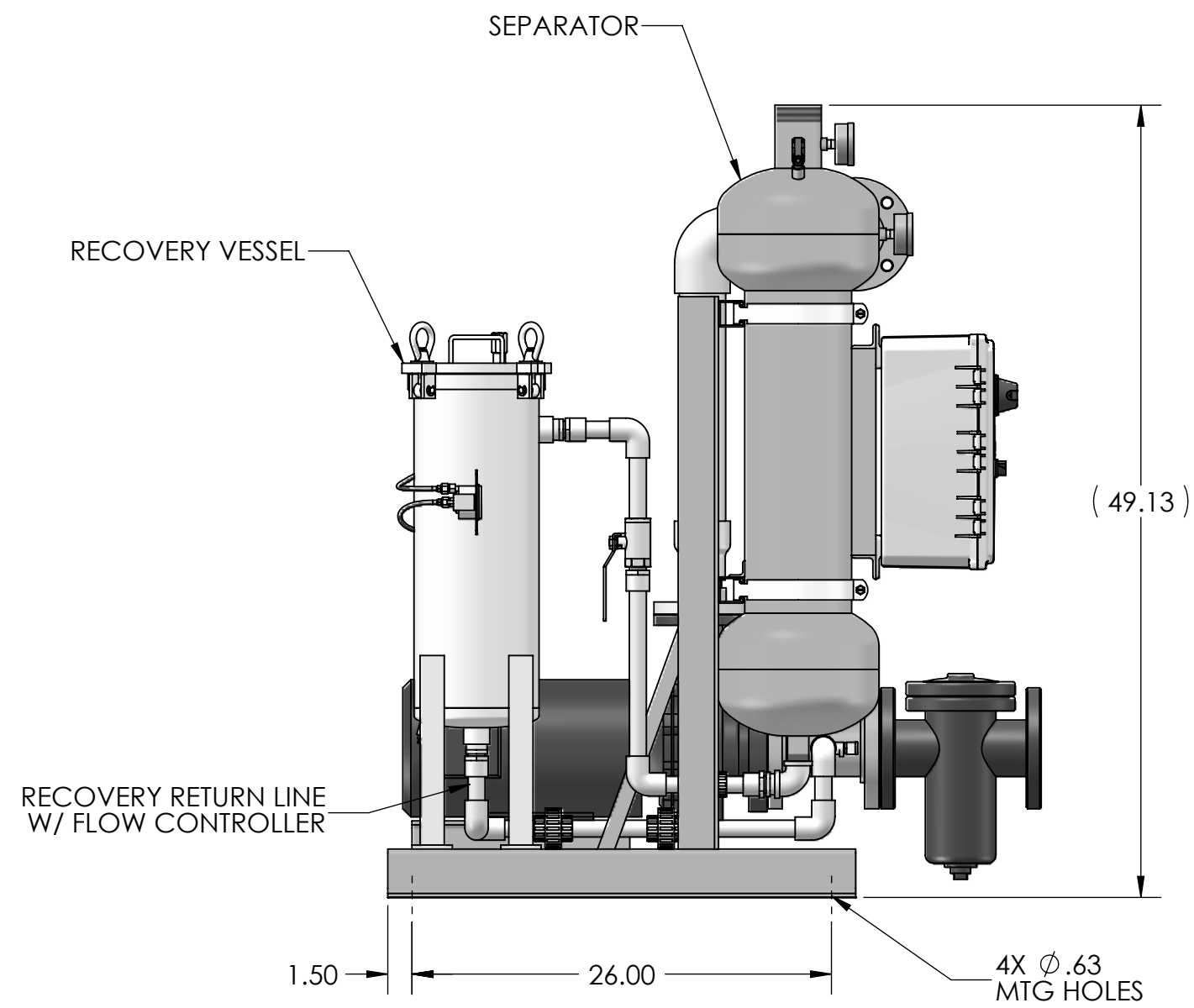
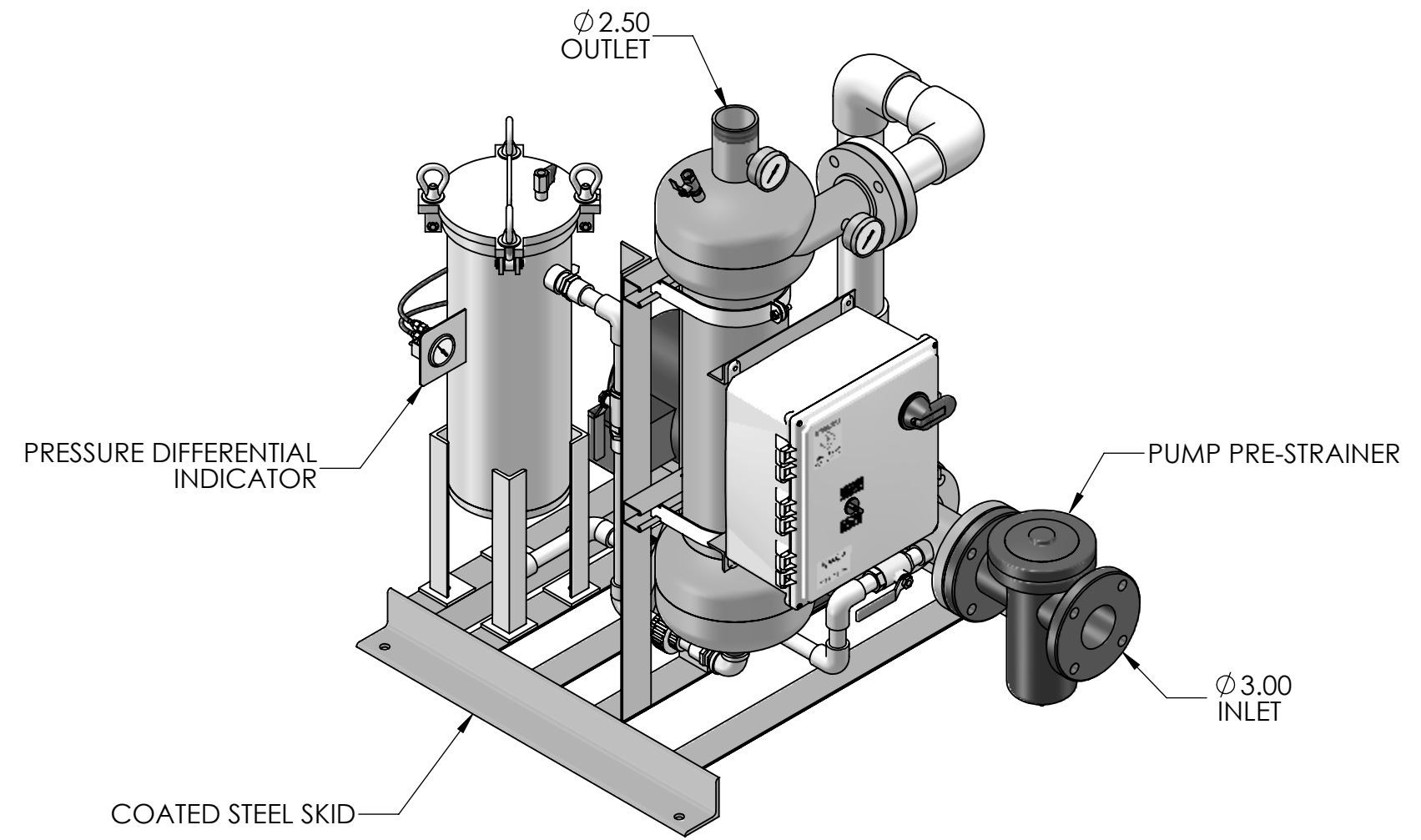
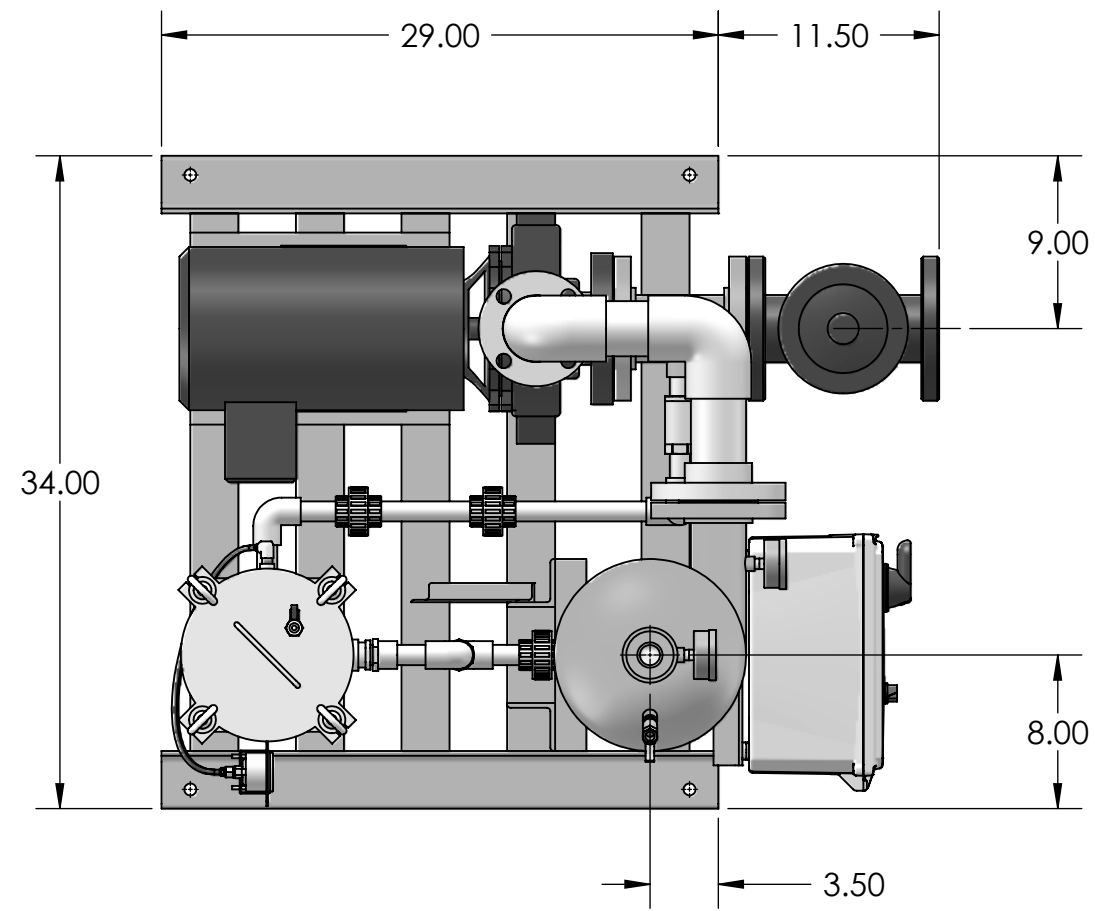

PROPRIETARY AND CONFIDENTIAL THE INFORMATION CONTAINED IN THIS DRAWING IS THE SOLE PROPERTY OF PUROFLUX CORPORATION. ANY REPRODUCTION IN PART OR AS A WHOLE WITHOUT THE WRITTEN PERMISSION OF PUROFLUX CORPORATION IS PROHIBITED.	PF-63-025 SEPARATOR PACKAGE 160 GPM - WITH RECOVERY VESSEL		
	SIZE DWG NO. 631-0530	REV -	
DRAWN C. NIELSEN	RELEASE DATE 6-6-16	SCALE NONE	WWW.PUROFLUX.COM
			SHEET 1 OF 1

4

3

2

1

REVISIONS			
REV	DESCRIPTION	DATE	APPROVED

POWER SUPPLY
LOCKABLE NON-FUSED
DISCONNECT SWITCH

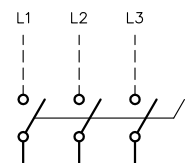

MCP

MR



PUMP MOTOR

PRIMARY FUSES

SECONDARY FUSE

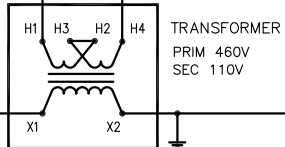

TRANSFORMER
PRIM 460V
SEC 110V

GND

PUMP
SELECTOR
SWITCH

LOCAL
OFF
REMOTE

MCP TRIP

MOTOR RELAY

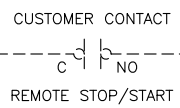

REMOTE STOP/START

PUMP MOTOR FULL LOAD AMPS (3 ϕ , 60Hz)				
MOTOR HP	208 VOLTS	230 VOLTS	460 VOLTS	575 VOLTS
2	6.44	5.6	2.8	2.24
3	9.59	8.34	4.17	3.34
5	15.5	13.5	5.76	5.41
7.5	22.4	19.5	9.79	7.81
10	29.2	25.4	12.7	10.1
15	45.1	39.2	19.6	15.7
20	58.9	51.2	25.6	20.5
25	74.5	64.8	32.4	25.9
30	86.9	75.6	37.8	30.2
40	116.0	101.0	50.4	40.3

FULL LOAD CURRENTS LISTED ABOVE ARE "AVERAGE VALUES" FOR HORSEPOWER RATED MOTORS OF SEVERAL MANUFACTURERS. THE RATED FULL LOAD CURRENT SHOWN ON THE MOTOR NAMEPLATE MAY VARY BY MANUFACTURER.

NOTES

- NOTES: UNLESS OTHERWISE SPECIFIED
- BRANCH CIRCUIT PROTECTION SUPPLIED BY OTHERS
 - PANEL U.L. LISTED AND LABELED
 - DASHED LINES INDICATE FIELD WIRING
 - SWITCH OPERATION
"LOCAL" - REMOTE STOP/START OVERRIDE
"OFF" - FILTER "OFF"
"AUTO" - FILTER ON/OFF VIA REMOTE STOP/STOP

WARNING

If an overload or fault current interruption occurs, circuits must be checked to determine the cause of the interruption. If a fault condition exists, the current carrying components should be examined and replaced if damaged, and the integral current sensors must be replaced to reduce the risk of fire or electric shock.

CAUTION - RISK OF ELECTRICAL SHOCK

More than one disconnect switch may be required to de-energize the equipment before servicing.

WARNING - RISK OF FIRE OR ELECTRIC SHOCK

The opening of the branch circuit protective device may be an indication that a fault current has been interrupted. All current carrying parts and other components protected by this device should be examined and replaced if damaged. If burnout of a current element of an overload relay occurs, the complete overload relay must be replaced.

ALTERNATE - 208V

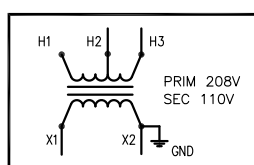

PRIM 208V
SEC 110V

ALTERNATE - 230V

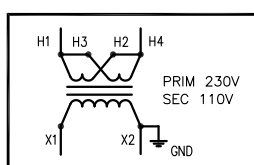

PRIM 230V
SEC 110V

ALTERNATE - 575V

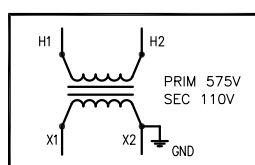

PRIM 575V
SEC 110V

PROPRIETARY AND CONFIDENTIAL
THE INFORMATION CONTAINED IN THIS DRAWING IS THE SOLE PROPERTY OF PUROFLUX CORPORATION. ANY REPRODUCTION IN PART OR AS A WHOLE WITHOUT THE WRITTEN PERMISSION OF PUROFLUX CORPORATION IS STRICTLY PROHIBITED.

U.L. CONTROL PANEL : PF-63 SERIES
CONTROL PANEL WITH PUMP HOA
SIZE C DWG NO. UL2-1921
DRAWN K. CARTER RELEASE DATE 7-15-16 SCALE NONE

PUROFLUX CORPORATION
WWW.PUROFLUX.COM
SHEET 1 OF 1

4

3

2

1