

PF-64H-025-AP SPECIFICATION SHEET PUMP PACKAGE SYSTEM

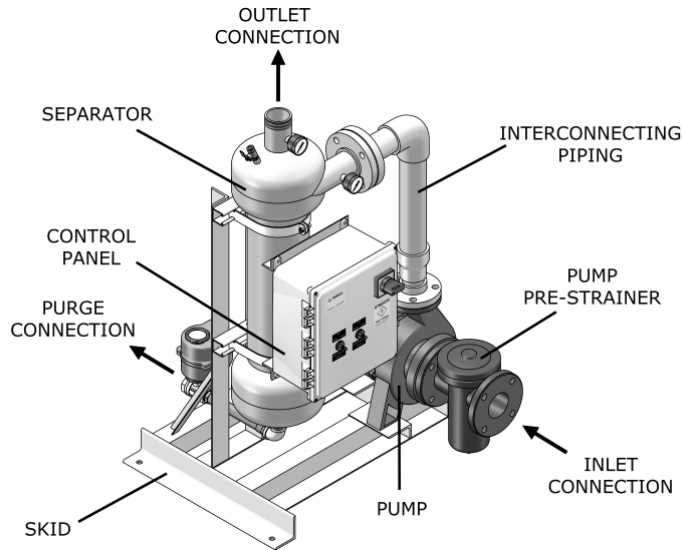

Features:

- Removes particulate as low as 45 microns
- 150 psi working pressure
- Fully assembled skid package
- One year limited warranty

Options:

- Manual purge
- Removable dome separator
- 22 1/2° Profile separator
- Coated carbon steel piping
- Isolation valve kit

SYSTEM COMPONENTS

| SPECIFICATIONS | PF-64H-025-AP |
|--------------------------|---------------|
| Flow Rate | 160 GPM |
| System Inlet Connection | 3" Flg |
| System Outlet Connection | 2 1/2" mpt |
| Purge Connection | 1" fpt |
| Separator Model | PF-61-025 |
| Separator Purge | Automatic |
| Pump Motor | 7.5 HP |
| Volume | 8 GAL |
| Est. Weight, Dry | 561 lbs |
| Est. Weight, Operating | 622 lbs |

Separator :

- PF-61 Series separator
- Fusion-bond polyester coated vessel
- Manual air bleed valve
- Inlet/Outlet pressure gauges

Electrical Controls :

- UL labeled control panel with NEMA 4X Enclosure
- Door disconnect switch
- Short circuit and Motor overload protection
- Hand-Off-Auto switches

Pump :

- Centrifugal pump
- TEFC motor
- Cast iron pre-strainer

Automatic Purge :

- Electrically actuated ball valve
- Adjustable purge timer

Skid :

- Fusion-bond polyester coated carbon steel

Interconnecting Pipe :

- Sch.80 PVC piping

NOTES: UNLESS OTHERWISE SPECIFIED

1. DIMENSIONS ARE IN INCHES
2. DIMENSIONS MAY VARY SLIGHTLY - DO NOT USE FOR CONSTRUCTION
3. SEPARATOR SYSTEM IS RATED FOR 150 PSI WORKING PRESSURE

| REVISIONS | | | |
|-----------|---------------------|----------|----------|
| REV | DESCRIPTION | DATE | APPROVED |
| A | REVISED PUMP & SKID | 10-23-12 | D.L. |

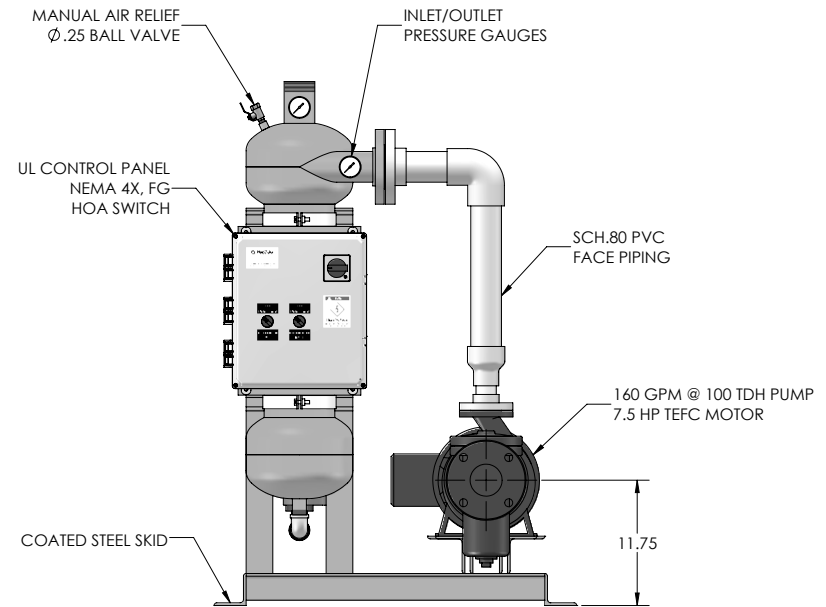
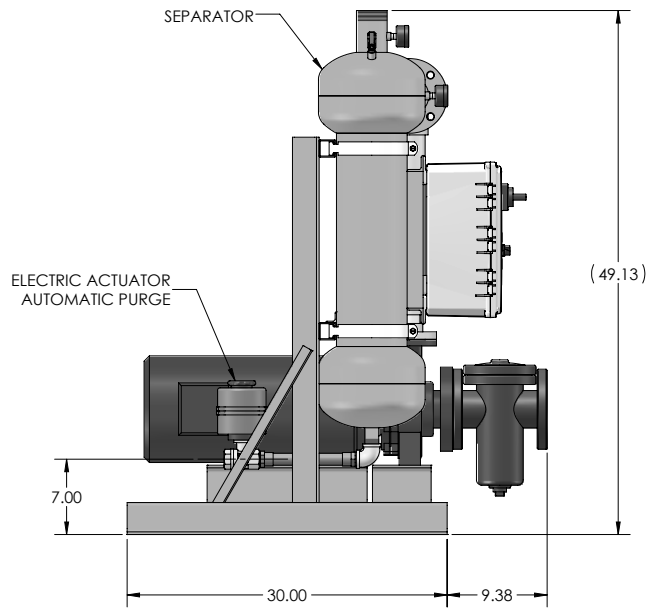
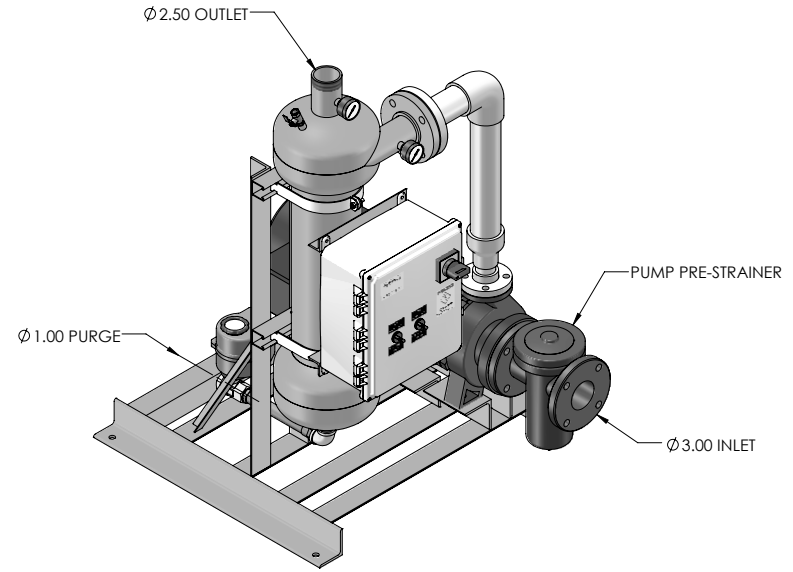
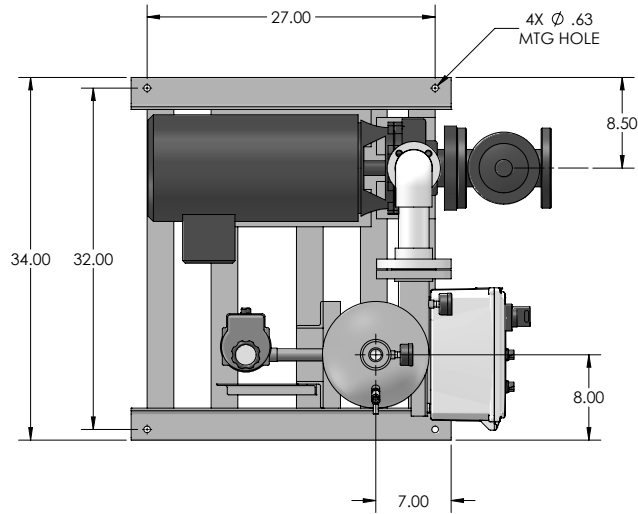

| | | | |
|--|---|--|--|
| PROPRIETARY AND CONFIDENTIAL THE INFORMATION CONTAINED IN THIS DRAWING IS THE SOLE PROPERTY OF PUROFLUX CORPORATION. ANY REPRODUCTION IN PART OR AS A WHOLE WITHOUT THE WRITTEN PERMISSION OF PUROFLUX CORPORATION IS PROHIBITED. | PF-64H-025-AP-UL SEPARATOR PACKAGE 160 GPM - W/SKID MOUNTED PUMP | |  PUROFLUX CORPORATION |
| | SIZE C DWG NO. 641-0404 DRAWN D. LUNA | REV A RELEASE DATE 11-17-10 SCALE NONE | |

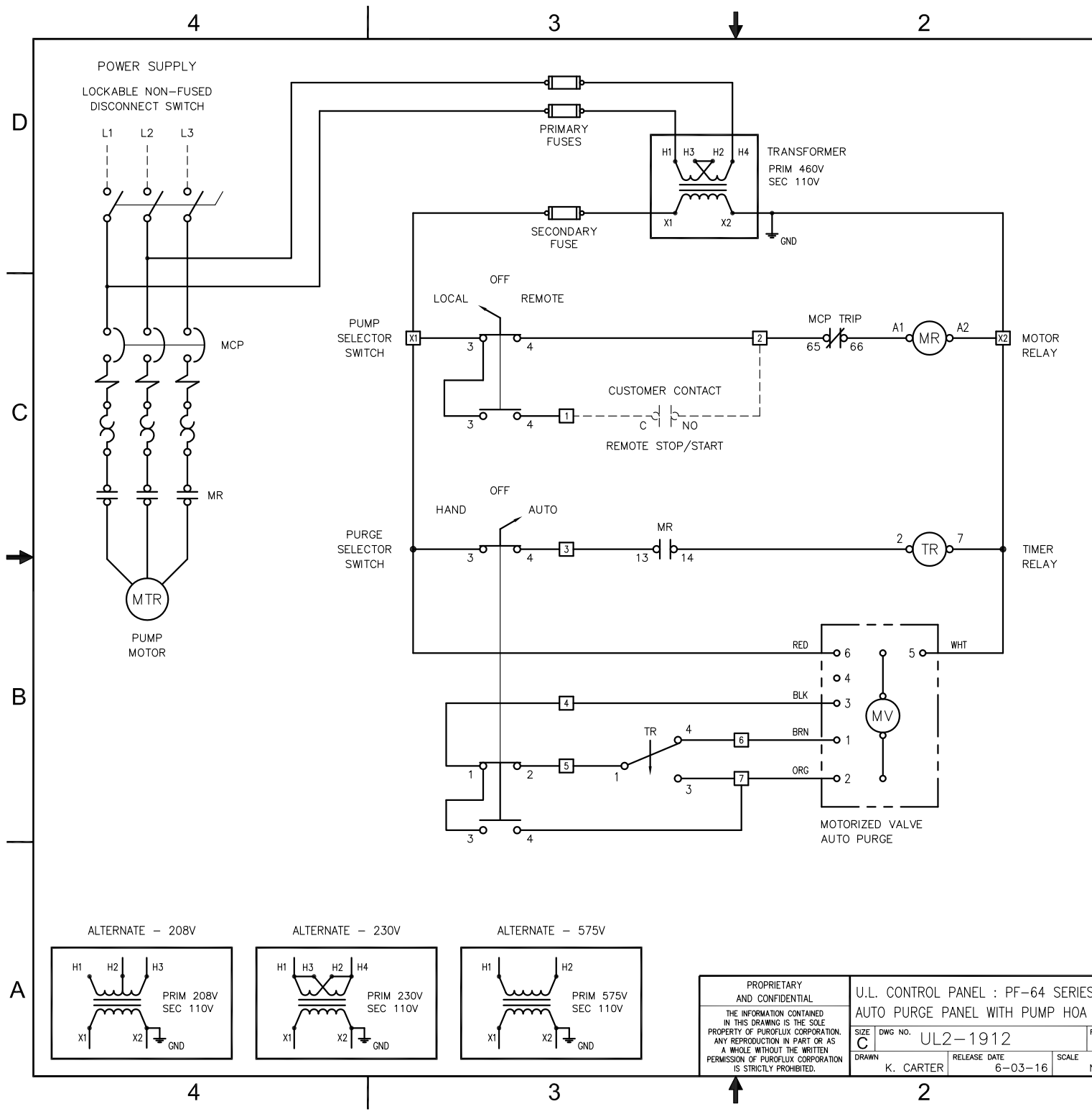

| REVISIONS | | | |
|-----------|-------------|------|----------|
| REV | DESCRIPTION | DATE | APPROVED |
| | | | |

| PUMP MOTOR FULL LOAD AMPS (3 ϕ , 60Hz) | | | | |
|--|-----------|-----------|-----------|-----------|
| MOTOR HP | 208 VOLTS | 230 VOLTS | 460 VOLTS | 575 VOLTS |
| 1 | 3.22 | 2.8 | 1.4 | 1.12 |
| 2 | 6.44 | 5.6 | 2.8 | 2.24 |
| 3 | 9.59 | 8.34 | 4.17 | 3.34 |
| 5 | 15.5 | 13.5 | 5.76 | 5.41 |
| 7.5 | 22.4 | 19.5 | 9.79 | 7.81 |
| 10 | 29.2 | 25.4 | 12.7 | 10.1 |

FULL LOAD CURRENTS LISTED ABOVE ARE "AVERAGE VALUES" FOR HORSEPOWER RATED MOTORS OF SEVERAL MANUFACTURERS. THE RATED FULL LOAD CURRENT SHOWN ON THE MOTOR NAMEPLATE MAY VARY BY MANUFACTURER.

- NOTES: UNLESS OTHERWISE SPECIFIED
1. BRANCH CIRCUIT PROTECTION SUPPLIED BY OTHERS
 2. PANEL U.L. LISTED AND LABELED
 3. DASHED LINES INDICATE FIELD WIRING
 4. SWITCH OPERATION
 "LOCAL" - REMOTE STOP/START OVERRIDE
 "OFF" - FILTER "OFF"
 "AUTO" - FILTER ON/OFF VIA REMOTE STOP/STOP

ACTUATOR WARNING !!!!

The emergency "MAN" switch and external hand wheel located on the filter actuator are only to be used when there is no power to the actuator. Disconnect power to the control panel before using this feature or DAMAGE MAY OCCUR to the actuator.

THIS FEATURE IS FOR EMERGENCIES ONLY!

If the valve does not open or close fully adjust cams to correct problem.

WARNING

If an overload or fault current interruption occurs, circuits must be checked to determine the cause of the interruption. If a fault condition exists, the current carrying components should be examined and replaced if damaged, and the integral current sensors must be replaced to reduce the risk of fire or electric shock.

CAUTION - RISK OF ELECTRICAL SHOCK

More than one disconnect switch may be required to de-energize the equipment before servicing.

WARNING - RISK OF FIRE OR ELECTRIC SHOCK

The opening of the branch circuit protective device may be an indication that a fault current has been interrupted. All current carrying parts and other components protected by this device should be examined and replaced if damaged. If burnout of a current element of an overload relay occurs, the complete overload relay must be replaced.

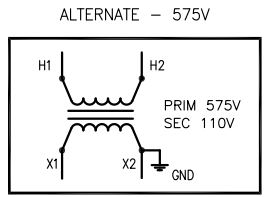
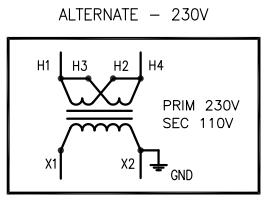
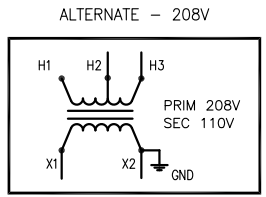

PROPRIETARY AND CONFIDENTIAL
 THE INFORMATION CONTAINED IN THIS DRAWING IS THE SOLE PROPERTY OF PUROFLUX CORPORATION. ANY REPRODUCTION IN PART OR AS A WHOLE WITHOUT THE WRITTEN PERMISSION OF PUROFLUX CORPORATION IS STRICTLY PROHIBITED.

U.L. CONTROL PANEL : PF-64 SERIES
 AUTO PURGE PANEL WITH PUMP HOA

SIZE C DWG NO. UL2-1912 REV -
 DRAWN K. CARTER RELEASE DATE 6-03-16 SCALE NONE

PUROFLUX CORPORATION

WWW.PUROFLUX.COM SHEET 1 OF 1